

CONTENT

IN GENERAL	3
ROOF	5
VENTILATED ROOF WITH RAFTERS/TOP FLANGES OF SOLID WOOD, GLUED LAMINATED WOOD OR LVL	6
COMPACT ROOF WITH MASONITE BEAMS	7
CEILING AGAINST COLD ATTIC	8
INTERIOR WALLS	9
EXTERIOR WALLS	14
BEAM STRUCTURE	19
SOUND BEAM STRUCTURE	21
COVERING	27
WINDOW	28

IN GENERAL

Assumptions

The structures shown are produced with Byggma products from Forestia AS for chipboard, Huntonit AS for wood fibreboard and MDF boards, Masonite Beams AB for I-beams and I-uprights and Uldal AS for windows. All structures will include products from other manufacturers. For these products, if the manufacturer and product are not stated, minimum values for product characteristics from product standards are used in the tables for fire, sound and U value. If test results are available, these are used, while for structures that have not been tested, calculated values are applied in accordance with the current standard, and from the SINTEF Building Research Design Guides.

Structural solutions describing installation and documented construction details are described in the construction details for the Masonite beam at www.masonite.no

For the board products, there are installation guides and other documentation at: www.forestia.no (chipboard) and www.huntonit.no (wood fibreboard and MDF boards).

Fire

For structures, the documented fire resistance is described, such as REI30, in beam structures, walls and roofs. The fire class and requirements of the structural surfaces are assumed to be described by the consulting engineer. Tables for the various structures show their fire resistance. Suppliers of other insulation types than mineral wool must document their fire properties.

Sound

For structures where this is relevant, the current sound insulation values are stated. For beam structures, values for airborne and impact sound are stated, while for exterior and interior walls the air/sound reduction is stated. Suppliers of other insulation types than mineral wool must document their sound properties.

U value

The U values of beam structures, and wall and roof structures, are calculated in accordance with NS-EN ISO 10211 and NS-EN-ISO 6946 in cooperation with SINTEF Building Research and follow the same principles as presented in their Building Research Design Guides.

The tables take account of the better λ value for the OSB step of Masonite beams and uprights, compared to the value used for other manufacturers' I profiles in the SINTEF Building Research construction details. The U values are calculated on the basis of the material types and qualities from which the structures are constructed, and this is described for each structure. Where not otherwise stated for the individual structure, mineral wool is assumed to be the insulation used. No other requirements are made of the supplier/product than that the λ value requirement is fulfilled with regard to U value.

Characteristics	U values (W/m ² K)		
	TEK10	Passive house	Low-energy house, class 1
Exterior wall*	0,18	0,10-0,12	0,15-0,16
Roof*	0,13	0,08-0,09	0,10-0,12
Floor*	0,10	0,08	0,10-0,12
Window and door	0,80	0,80	1,2
Sealing	0,6	0,6	1,0
Thermal bridge	0,05	0,03	0,05

Table showing U values for TEK10, passive house and low-energy house, class 1.

*The U values for passive and low-energy house are from NS 3700:2013 and are average values.

For TEK10, re-distribution between the structures is permitted, so that e.g. walls can be made thinner than the U value would indicate, while the roof and/or window, for example, are above the minimum requirement.

IN GENERAL

TEK10				Passive house				Low-energy house, class 1			
Construction	Insulation quality λ_d (W/mK)			Construction	Insulation quality λ_d (W/mK)			Construction	Insulation quality λ_d (W/mK)		
	0,032	0,035	0,037		0,032	0,035	0,037		0,032	0,035	0,037
	Minimum dimensions				Minimum dimensions				Minimum dimensions		
Exterior wall	R200	R250	R250	Exterior wall	R300-R400	R350-400	R350-R400	Exterior wall	R250	R250-R300	R250-R300
Roof	H300	H300	H350	Roof	H400-H450	H450-H500	H450-H500	Roof	H300-H350	H350-H400	H350-H400
Floor	H350	H400	H400	Floor	H450	H500	H500	Floor	H300-H350	H350-H400	H350-H400

The tables present an overview with proposed minimum dimensions, depending on the insulation's quality, the wall structure and the regulations' requirements concerning U value. For walls, a detached house with a normal door and window area with a wood ratio of $L''=3.5\text{m}^2$ is assumed. The relevant structure must nonetheless be controlled against Byggma's U-value tables or by own calculations.

Energy efficiency and thermal bridge values

In most cases, there will be a greater heat loss in transitions between structural elements than in the actual wall, e.g. between wall and beam structure/covering/roof structures, and against wall columns, etc. This extra heat loss is calculated with the help of "thermal bridge values" and must be considered on calculating the building's energy efficiency. The thermal bridge value can be found in several ways:

1. Select the standard value from table A.4 in NS 3031:2014
2. Find in the SINTEF Building Research thermal bridge atlas.
3. Perform own calculations, which requires a lot of skill.

In most cases, alternative 1 or 2 will be selected. For I-profiles such as Masonite beams and uprights, thermal bridge values are calculated for a number of structures in the SINTEF Building Research thermal bridge atlas.

ROOF

Roof structures with rafters, purlins or top flanges of Masonite beams or timber. Timber is solid wood, glued laminated wood and LVL (laminated veneer lumber).

U value

The tables are developed in collaboration with SINTEF Building Research. Material properties for chipboard with a minimum thickness of 12 mm, and wood fibreboard and MDF boards with a minimum thickness of 11 mm, are used. If other ceiling materials are to be used, they must have minimum the same characteristics with regard to U value as the aforementioned chipboard, wood fibreboard and MDF boards.

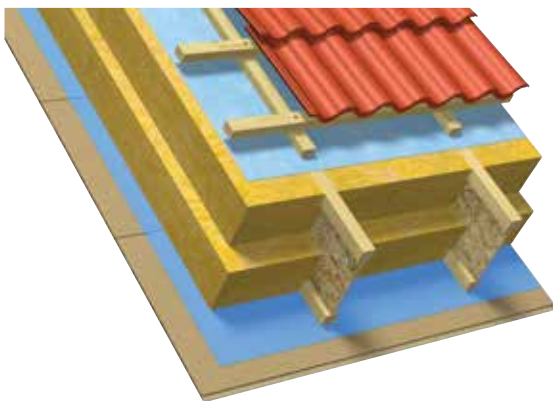

Fig. 1 Roof
Ventilated roof with foil underlay for roof tiles.

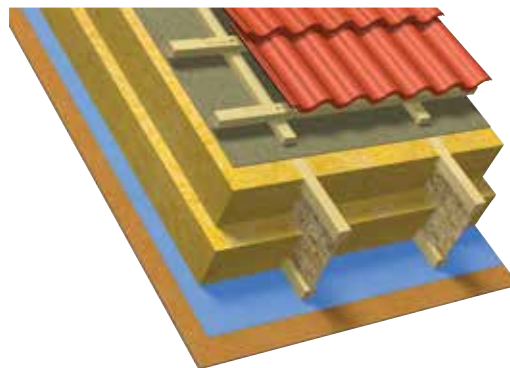

Fig. 2 Roof
Ventilated roof with wood fibreboard for roof tiles.

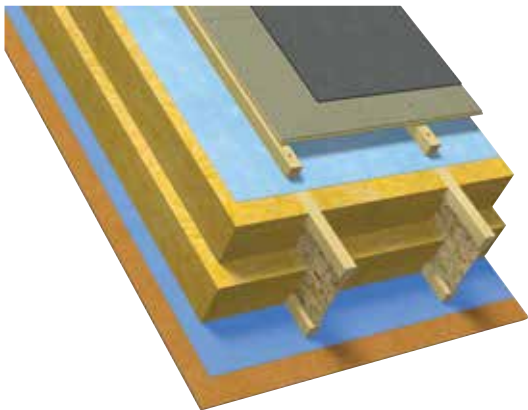

Fig. 3 Roof
Ventilated roof with roof sheathing and roofing felt/foil.

Beam height and insulation thickness	U values (W/m ² K)		
	Insulation with heat conductivity		
	$\lambda_d=0,032$	$\lambda_d=0,035$	$\lambda_d=0,037$
200	0,172	0,185	0,194
220	0,157	0,169	0,177
250	0,138	0,149	0,156
300	0,116	0,125	0,131
350	0,100	0,107	0,113
400	0,087	0,094	0,099
450	0,078	0,084	0,088
500	0,070	0,076	0,079

VENTILATED ROOF WITH RAFTERS/TOP FLANGES OF SOLID WOOD, GLUED LAMINATED WOOD OR LVL

The same structure is assumed as shown in Figures 1-3 Roof, but rafters/top flanges are replaced with solid wood, glued laminated wood or LVL. The rafter thickness is 48 mm.

Beam height and insulation thickness	U values (W/m ² K)		
	Insulation with heat conductivity		
	$\lambda_d=0,032$	$\lambda_d=0,035$	$\lambda_d=0,037$
200	0,181	0,193	0,201
220	0,166	0,177	0,184
250	0,147	0,157	0,164
300	0,124	0,132	0,138

COMPACT ROOF WITH MASONITE BEAMS

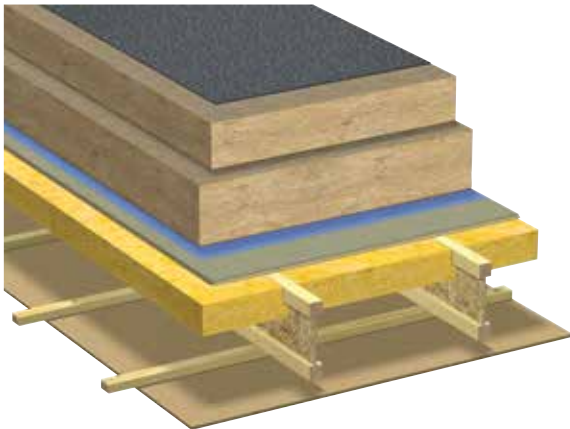

Beam height and insulation thickness	U values (W/m ² K)		
	Insulation with heat conductivity		
	$\lambda_d=0,032$	$\lambda_d=0,035$	$\lambda_d=0,037$
300	0,100	0,109	0,115
350	0,087	0,094	0,099
400	0,076	0,083	0,088
450	0,068	0,074	0,078
500	0,062	0,067	0,071

Fig. 4 Roof
 Compact roof
 Compressive insulation and diffusion barrier on the underlay.
 Maximum 1/4 of the insulation below the underlay.

CEILING AGAINST COLD ATTIC



Fig. 5 Roof
Ceiling against cold attic.

Beam height and insulation thickness	U values (W/m ² K)		
	Insulation with heat conductivity		
	$\lambda_d=0,032$	$\lambda_d=0,035$	$\lambda_d=0,037$
200	0,166	0,178	0,186
220	0,151	0,162	0,170
250	0,134	0,144	0,150
300	0,113	0,121	0,127
350	0,097	0,105	0,110
400	0,085	0,092	0,096
450	0,076	0,082	0,086
500	0,069	0,074	0,078

INTERIOR WALLS

Interior walls with uprights and sills of timber or steel profiles, insulated with mineral wool. Timber-based boards, chipboard from Forestia AS, wood fibreboard and MDF boards, Huntonit. The boards are installed in one or several layers.

Fire resistance

Wood-based boards must have a minimum thickness of 9 mm and a density of at least 600 kg/m³. Wood fibreboard and MDF boards must have a minimum thickness of 11 mm. If a different thickness is required, this is described for the relevant detail/figure.

All board types classified in "K210 A2-s1,d0" (K1-A), "K210 B-s1,d0" (K1) and "K210 D-s2, d0" (K2).

Sound reduction

Chipboard must be minimum 12 mm thick, while wood fibreboard and MDF boards must be minimum 11 mm thick. If a different thickness is required, this is described for the relevant detail/figure.

Alternative materials

Some of the interior walls have alternative materials. For these, there are remarks in the tables and a related table showing the change in materials and its consequences for sound and fire properties.



Insulation thickness (mm)	Upright dimensions (mm)	Sound reduction (dB)	Fire resistance	Remark
70	36x73	37-39	EI30	
100	48x98	40-43	EI30	1)

Remark	Change	Sound reduction (dB)	Fire resistance
1)	Stone wool insulation	40-43	EI60/REI30

Fig. 1 Interior wall
Continuous timber upright. One layer of board.

INTERIOR WALL



Insulation thickness (mm)	Upright dimensions (mm)	Sound reduction (dB)	Fire resistance
100	36x73	45	EI30
120	36x98	46	EI30

Fig. 2 Interior wall
Displaced timber upright on timber sill.
Two board layers.



Insulation thickness (mm)	Upright dimensions (mm)	Sound reduction (dB)	Fire resistance
100	36x73	50	EI30
120	36x98	50-51	EI30

Fig. 3 Interior wall
Displaced timber upright on timber sill.
Two board layers.

INTERIOR WALL



Fig. 4 Interior wall
Double timber upright. Two board layers.

Insulation thickness (mm)	Upright dimensions (mm)	Sound reduction (dB)	Fire resistance	Remark
2x70	48x73	54	REI30	1), 3)
2x100	48x98	55	REI30	2)

Remark	Change	Sound reduction (dB)	Fire resistance
1)	2x70 mm stone wool One layer of 16 mm chipboard and one layer of 12/11 mm boards on each side	56	REI60
2)	13 mm gypsum board and 12 mm Forestia, possibly 11 mm Huntonit or 11 mm Focus MDF board outermost	55	REI60
3)	2x70 mm mineral wool. One layer of 16 mm chipboard and one layer of 12/11 mm boards on each side	54	EI60

INTERIOR WALL



Insulation thickness (mm)	Upright dimensions (mm)	Sound reduction (dB)	Fire resistance	Remark
70	75	42	EI30	1)
100	95	43	EI30	2)

Remark	Change	Sound reduction (dB)	Fire resistance
1)	Two layers of panel on both sides	47	EI30
2)	Two layers of panel on both sides	48	EI30

Fig. 5 Interior wall
Continuous steel upright with one board layer.

INTERIOR WALL



Insulation thickness (mm)	Upright dimensions (mm)	Sound reduction (dB)	Fire resistance	Remark
100	2x75	52	E130	1)

Remark	Change	Sound reduction (dB)	Fire resistance
1)	One layer of panel	47	E130

Fig. 6 Interior wall
Displaced steel upright with two board layers.

EXTERIOR WALLS

U value

In the tables for Masonite uprights, upright quality (type R) is used. The tables are developed in collaboration with SINTEF Building Research and the same calculation assumptions are used as described in their Building Research Design Series, construction detail 471.231.

The U values stated in the tables are calculated for walls with different numbers of metres of studwork per m² of net wall area, L". If own calculations of L" give another value than specified in the tables, interpolation between the U values can be used. See the calculation method and examples in the Building Research Design Series.

The table for the timber ratio, L", is taken from construction detail 471.231 and shows examples of structures and related L".

Table for timber ratio, L"

Type of façade		L" (m/m ²) Studwork 2)
Area ratio windows and doors in façade (%)	Example of wall/building 1)	
0	Wall with a height of 2.4 m outside windows and doors	2,45
17	Detached home, room height 2.4 m	3,50
30	Residential block, terraced house, nursery school, room height 2.4 m	4,50
39	Large commercial building, room height 3.5 m	5,50
46	Large commercial building, room height 2.6m	6,50
51	Large building with a room height of 2.6 m and windows with non-standard geometry in the studwork	7,50

1) The same building carcass and geometry are assumed as the technical requirements of building structures (TEK10) are based on, with a total window area of 20% of area used and typical window size.

2) Uprights with c/c 0.6 m, with single base and top sills, supplemented with extra uprights and noggings as reinforcement around windows and doors, in the same material as the uprights.

Sound reduction

Sound reduction, R_w , is indicative and based on the laboratory-measured sound reduction figure R_w in SINTEF Building Research, construction detail 523.422. R_w is the field-measured figure and is set 5 dB lower than R_w . For walls that are to insulate from road traffic noise, account should be taken of the reversal figure C_{tr} , which reduces the size of R_w .

Fire resistance

Fire resistance is based on calculations and tests.

EXTERIOR WALL



Fig. 1 Exterior wall
Masonite upright. Foil wind barrier.



Fig. 2 Exterior wall
Masonite upright, foil wind barrier with interior crosser liner.

Insulation (mm)	Stud-work + feed	U values [W/(m ² K)]																		Sound reduction R _w (dB)
		Insulation with heat conductivity (λ _d), [W/(mK)]																		
		λ _d =0,032						λ _d =0,035						λ _d =0,037						
		Area-specific length, I-beam (L''), [m/m ²]						Area-specific length, I-beam (L''), [m/m ²]						Area-specific length, I-beam (L''), [m/m ²]						
		L''=2,45	L''=3,5	L''=4,5	L''=5,5	L''=6,5	L''=7,5	L''=2,45	L''=3,5	L''=4,5	L''=5,5	L''=6,5	L''=7,5	L''=2,45	L''=3,5	L''=4,5	L''=5,5	L''=6,5	L''=7,5	
200	200	0,179	0,191	0,202	0,213	0,224	0,235	0,191	0,203	0,214	0,224	0,235	0,246	0,200	0,211	0,222	0,233	0,244	0,254	ca. 40
250	200+48	0,145	0,156	0,166	0,177	0,187	0,197	0,156	0,166	0,177	0,187	0,197	0,207	0,163	0,173	0,183	0,194	0,204	0,214	
	250	0,144	0,153	0,162	0,171	0,180	0,190	0,154	0,164	0,172	0,181	0,190	0,199	0,161	0,170	0,178	0,186	0,195	0,203	
300	250+48	0,121	0,130	0,138	0,147	0,155	0,163	0,130	0,139	0,147	0,155	0,163	0,171	0,136	0,145	0,153	0,161	0,169	0,177	
	300	0,120	0,128	0,135	0,142	0,149	0,156	0,129	0,137	0,143	0,150	0,157	0,164	0,135	0,142	0,149	0,156	0,163	0,170	
350	300+48	0,104	0,111	0,118	0,125	0,132	0,139	0,112	0,119	0,125	0,131	0,138	0,144	0,117	0,124	0,131	0,137	0,144	0,151	
	350	0,103	0,110	0,116	0,122	0,128	0,134	0,111	0,117	0,123	0,129	0,135	0,141	0,116	0,122	0,128	0,134	0,140	0,146	
400	350+48	0,091	0,097	0,103	0,109	0,115	0,120	0,098	0,104	0,110	0,115	0,121	0,127	0,103	0,109	0,114	0,120	0,126	0,131	
	400	0,091	0,096	0,101	0,107	0,112	0,117	0,098	0,103	0,108	0,113	0,118	0,123	0,102	0,107	0,113	0,118	0,123	0,128	

EXTERIOR WALL



Fig. 3 Masonite upright, wind barrier, 12 mm wood fibreboard.

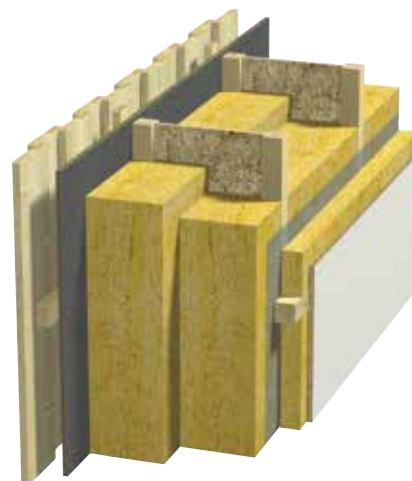

Fig. 4 Exterior wall Masonite upright, wind barrier of 12 mm wood fibreboard with interior crosser liner.

Insulation (mm)	Stud-work + feed	U values [W/(m ² K)]																		Sound reduction R _w (dB)
		Insulation with heat conductivity (λ _d), [W/(mK)]																		
		λ _d =0,032						λ _d =0,035						λ _d =0,037						
		Area-specific length, I-beam (L''), [m/m ²]						Area-specific length, I-beam (L''), [m/m ²]						Area-specific length, I-beam (L''), [m/m ²]						
		L''=2,45	L''=3,5	L''=4,5	L''=5,5	L''=6,5	L''=7,5	L''=2,45	L''=3,5	L''=4,5	L''=5,5	L''=6,5	L''=7,5	L''=2,45	L''=3,5	L''=4,5	L''=5,5	L''=6,5	L''=7,5	
200	200	0,172	0,182	0,192	0,202	0,213	0,223	0,183	0,194	0,203	0,213	0,223	0,233	0,191	0,201	0,211	0,220	0,230	0,240	ca. 41
250	200+48	0,140	0,151	0,161	0,171	0,181	0,191	0,150	0,160	0,170	0,180	0,190	0,199	0,157	0,167	0,176	0,186	0,195	0,204	
	250	0,139	0,148	0,156	0,164	0,172	0,181	0,149	0,157	0,165	0,173	0,181	0,189	0,155	0,164	0,172	0,180	0,187	0,195	
300	250+48	0,118	0,126	0,134	0,142	0,150	0,158	0,126	0,135	0,142	0,150	0,158	0,165	0,132	0,140	0,147	0,154	0,161	0,169	
	300	0,117	0,124	0,131	0,138	0,144	0,151	0,126	0,133	0,139	0,146	0,153	0,159	0,131	0,138	0,144	0,151	0,157	0,164	
350	300+48	0,102	0,109	0,115	0,122	0,128	0,135	0,109	0,116	0,122	0,129	0,136	0,142	0,114	0,121	0,127	0,133	0,139	0,146	
	350	0,101	0,107	0,113	0,119	0,124	0,130	0,108	0,115	0,120	0,126	0,132	0,138	0,113	0,119	0,125	0,131	0,136	0,142	
400	350+48	0,089	0,095	0,101	0,107	0,112	0,118	0,096	0,102	0,107	0,113	0,118	0,124	0,100	0,106	0,112	0,117	0,123	0,128	
	400	0,089	0,094	0,099	0,104	0,109	0,114	0,095	0,101	0,106	0,111	0,115	0,120	0,100	0,105	0,109	0,114	0,119	0,123	

EXTERIOR WALL



Fig. 5 Exterior wall
Timber upright, foil wind barrier.



Fig. 6 Exterior wall
Timber upright, foil wind barrier with interior crosser liner.

Insulation (mm)	Stud-work + feed	U values [W/(m²K)]																		Sound reduction R _w (dB)	Fire resistance			
		Insulation with heat conductivity (λ _d), [W/(mK)]																						
		λ _d =0,032						λ _d =0,035						λ _d =0,037										
		Area-specific length, I-beam (L''), [m/m²]						Area-specific length, I-beam (L''), [m/m²]						Area-specific length, I-beam (L''), [m/m²]										
d	t	L''=2,45	L''=3,5	L''=4,5	L''=5,5	L''=6,5	L''=7,5	L''=2,45	L''=3,5	L''=4,5	L''=5,5	L''=6,5	L''=7,5	L''=2,45	L''=3,5	L''=4,5	L''=5,5	L''=6,5	L''=7,5	Without crossings 38 dB With crossings 43dB	REI30			
150	148	36	0,239	0,255	0,271	0,286	0,302	0,317	0,254	0,270	0,285	0,299	0,314	0,329	0,265	0,279	0,293	0,307	0,321			0,335	Without crossings 38 dB With crossings 43dB	REI30
200	148+48	36	0,182	0,197	0,212	0,226	0,240	0,255	0,195	0,209	0,223	0,237	0,251	0,265	0,203	0,217	0,231	0,245	0,258	0,272				
	198	36	0,184	0,197	0,210	0,222	0,235	0,247	0,196	0,209	0,221	0,233	0,245	0,257	0,204	0,216	0,228	0,240	0,251	0,263				
250	198+48	36	0,148	0,160	0,172	0,184	0,195	0,207	0,158	0,170	0,182	0,193	0,204	0,216	0,165	0,177	0,188	0,199	0,210	0,221				
	246	36	0,150	0,161	0,172	0,182	0,193	0,203	0,160	0,171	0,181	0,191	0,201	0,211	0,167	0,177	0,187	0,197	0,207	0,217				
300	246+48	36	0,126	0,136	0,146	0,156	0,165	0,175	0,134	0,144	0,154	0,164	0,174	0,183	0,140	0,150	0,159	0,169	0,178	0,188				
	296	36	0,127	0,136	0,145	0,154	0,163	0,172	0,135	0,144	0,153	0,162	0,170	0,179	0,141	0,149	0,158	0,166	0,175	0,183				
350	296+48	36	0,109	0,117	0,126	0,134	0,143	0,151	0,116	0,125	0,133	0,141	0,150	0,158	0,121	0,130	0,138	0,146	0,154	0,163				
150	148	48	0,251	0,273	0,294	0,314	0,335	0,355	0,267	0,287	0,306	0,325	0,344	0,364	0,276	0,296	0,315	0,333	0,352	0,371	Without crossings 38 dB With crossings 43dB	REI30		
	200	148+48	48	0,189	0,208	0,226	0,244	0,262	0,280	0,201	0,219	0,237	0,254	0,271	0,288	0,210	0,227	0,244	0,260	0,277				
198		48	0,194	0,211	0,228	0,244	0,261	0,277	0,206	0,222	0,238	0,254	0,270	0,286	0,213	0,230	0,245	0,261	0,276	0,292				
250	198+48	48	0,154	0,170	0,184	0,199	0,214	0,228	0,164	0,179	0,193	0,207	0,221	0,235	0,171	0,186	0,200	0,213	0,227	0,241				
	246	48	0,159	0,173	0,187	0,201	0,215	0,229	0,169	0,183	0,196	0,210	0,223	0,237	0,175	0,189	0,202	0,215	0,228	0,241				
300	246+48	48	0,131	0,145	0,157	0,170	0,183	0,196	0,140	0,153	0,165	0,177	0,190	0,202	0,146	0,158	0,170	0,181	0,193	0,205				
	296	48	0,134	0,146	0,157	0,169	0,180	0,192	0,142	0,154	0,165	0,176	0,187	0,198	0,147	0,159	0,170	0,180	0,191	0,202				
350	296+48	48	0,114	0,125	0,137	0,148	0,159	0,170	0,121	0,132	0,142	0,153	0,163	0,174	0,126	0,137	0,147	0,158	0,168	0,178				

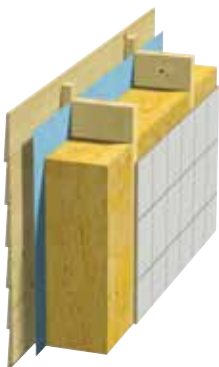

Fig. 7 Exterior wall
Timber upright. If bathroom panels from Fibo-Trespo are used, no diffusion barrier must be used behind this.

EXTERIOR WALL



Fig. 8 Exterior wall
Timber upright, wind barrier, 12 mm wood fibre-board.

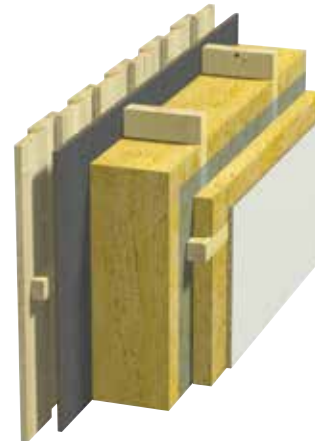

Fig. 9 Exterior wall
Timber upright, wind barrier of 12 mm wood fibre-board with interior crosser liner.

Insulation (mm)	Stud-work	U values [W/(m ² K)]																		Sound reduction R'w (dB)	Fire resistance																	
		Insulation with heat conductivity (λd), [W/(mK)]																																				
		λ _d =0,032						λ _d =0,035						λ _d =0,037																								
		Area-specific length, I-beam (L'), [m/m ²]						Area-specific length, I-beam (L''), [m/m ²]						Area-specific length, I-beam (L'''), [m/m ²]																								
d	t	L''=2,45	L''=3,5	L''=4,5	L''=5,5	L''=6,5	L''=7,5	L'''=2,45	L'''=3,5	L'''=4,5	L'''=5,5	L'''=6,5	L'''=7,5	L''''=2,45	L''''=3,5	L''''=4,5	L''''=5,5	L''''=6,5	L''''=7,5	Without crossings 38 dB With crossings 43dB	REI30																	
150	148	36	0,226	0,240	0,253	0,267	0,280	0,293	0,240	0,254	0,267	0,279	0,292	0,305	0,250	0,263	0,276	0,288	0,301			0,313	Without crossings 38 dB With crossings 43dB	REI30														
200	148+48	36	0,175	0,188	0,201	0,214	0,227	0,240	0,187	0,199	0,211	0,223	0,235	0,247	0,194	0,206	0,218	0,230	0,242			0,253			Without crossings 38 dB With crossings 43dB	REI30												
	198	36	0,176	0,188	0,199	0,210	0,221	0,232	0,187	0,198	0,209	0,219	0,230	0,241	0,195	0,206	0,216	0,227	0,237			0,248					Without crossings 38 dB With crossings 43dB	REI30										
250	198+48	36	0,143	0,154	0,165	0,176	0,186	0,197	0,153	0,163	0,174	0,184	0,194	0,204	0,159	0,170	0,180	0,190	0,200			0,211							Without crossings 38 dB With crossings 43dB	REI30								
	246	36	0,145	0,155	0,165	0,174	0,184	0,193	0,155	0,164	0,173	0,183	0,192	0,201	0,161	0,170	0,179	0,187	0,196			0,205									Without crossings 38 dB With crossings 43dB	REI30						
300	246+48	36	0,122	0,132	0,141	0,150	0,160	0,169	0,130	0,139	0,148	0,157	0,166	0,174	0,136	0,145	0,153	0,162	0,171			0,179											Without crossings 38 dB With crossings 43dB	REI30				
	296	36	0,123	0,132	0,140	0,148	0,157	0,165	0,131	0,139	0,147	0,155	0,163	0,171	0,136	0,144	0,152	0,160	0,168			0,176													Without crossings 38 dB With crossings 43dB	REI30		
350	296+48	36	0,106	0,114	0,122	0,130	0,138	0,147	0,113	0,121	0,129	0,137	0,145	0,152	0,118	0,126	0,133	0,141	0,149			0,156															Without crossings 38 dB With crossings 43dB	REI30
150	148	48	0,237	0,255	0,273	0,291	0,308	0,326	0,251	0,268	0,285	0,302	0,318	0,335	0,260	0,277	0,293	0,309	0,325			0,341																
	200	148+48	48	0,189	0,198	0,214	0,230	0,246	0,262	0,192	0,208	0,224	0,239	0,254	0,270	0,200	0,216	0,231	0,246	0,261	0,276	Without crossings 38 dB With crossings 43dB																
198		48	0,194	0,201	0,216	0,231	0,246	0,261	0,196	0,211	0,224	0,238	0,252	0,266	0,203	0,217	0,231	0,245	0,258	0,272	Without crossings 38 dB With crossings 43dB		REI30															
250	198+48	48	0,149	0,163	0,176	0,190	0,203	0,217	0,158	0,172	0,185	0,198	0,210	0,223	0,165	0,178	0,190	0,203	0,215	0,228				Without crossings 38 dB With crossings 43dB	REI30													
	246	48	0,153	0,166	0,179	0,192	0,205	0,218	0,162	0,175	0,187	0,199	0,211	0,223	0,168	0,180	0,192	0,204	0,215	0,227						Without crossings 38 dB With crossings 43dB	REI30											
300	246+48	48	0,127	0,139	0,151	0,163	0,175	0,186	0,135	0,147	0,158	0,169	0,180	0,192	0,141	0,152	0,163	0,174	0,185	0,197								Without crossings 38 dB With crossings 43dB	REI30									
	296	48	0,130	0,141	0,152	0,163	0,174	0,185	0,137	0,148	0,159	0,170	0,180	0,191	0,142	0,153	0,163	0,174	0,184	0,194										Without crossings 38 dB With crossings 43dB	REI30							
350	296+48	48	0,111	0,121	0,132	0,142	0,152	0,163	0,118	0,128	0,138	0,148	0,158	0,168	0,122	0,133	0,142	0,152	0,162	0,172												Without crossings 38 dB With crossings 43dB	REI30					

BEAM STRUCTURE

Beam structure above uninsulated room of Masonite beam or timber. Timber is solid wood, glued laminated wood and LVL (laminated veneer lumber).

Beam structure

The beam structures are shown in the tables for each figure.

U value

The beam structure tables are for beam structures above uninsulated, ventilated rooms. For beam structures to the outdoors, such as beam structures on piles/columns, the U value is 3-0% higher, with the greatest difference for the lowest beam heights. For beam heights of 350 and 400 mm, which satisfy TEK10 in terms of U value, the difference is 1-2%.



BEAM STRUCTURE	
Underfloor	22 mm Forestia chipboard floor
Floor beam	Masonite I-beam
Insulation	I-beam insulation with a thickness as the beam height of mineral wool, with U values in accordance with the table; other insulation must have documented fire characteristics.
Ceiling	23x48 laths, c/c 600 mm attached directly under the floor beams. One layer of 11 mm Focus MDF board, alternatively a layer of 12 mm Forestia chipboard, or a layer of 11 mm Huntonit wood fibreboard. 1) If 13 mm standard gypsum boards and rockwool insulation are used, the fire resistance is increased to REI30.

Fig. 1 Beam structure
Masonite floor beams, fully insulated with ceiling attached directly to the floor beams 1).

Beam height and insulation thickness	U values (W/m ² K)			Fire resistance
	Insulation with heat conductivity			
	$\lambda_d=0,032$	$\lambda_d=0,035$	$\lambda_d=0,037$	
200	0,166	0,178	0,186	REI15 1)
220	0,152	0,163	0,170	
250	0,135	0,144	0,151	
300	0,113	0,121	0,127	
350	0,097	0,104	0,110	
400	0,086	0,092	0,097	
450	0,076	0,082	0,086	
500	0,069	0,075	0,077	

BEAM STRUCTURE

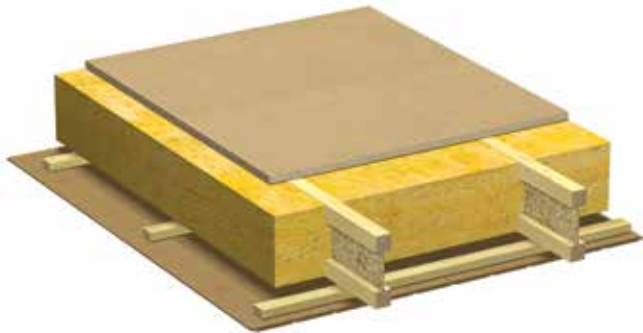

Fig. 2 Beam structure
Masonite floor beams, fully insulated, with ceiling on laths attached directly to the floor beams 1).

BEAM STRUCTURE	
Underfloor	22 mm Forestia chipboard floor
Floor beam	Timber, glued laminated wood or LVL
Insulation	Insulation with a thickness as the beam height of mineral wool, with U values in accordance with the table; other insulation must have documented fire characteristics
Ceiling	23x48 laths, c/c 600 mm attached directly under the floor beams. One layer of 11 mm Focus MDF board, alternatively a layer of 12 mm Forestia chipboard, or a layer of 11 mm Huntonit wood fibreboard. 1) If 13 mm standard gypsum boards are used, the fire resistance is increased to REI30.

Beam height and insulation thickness	U values (W/m ² K)			Fire resistance
	Insulation with heat conductivity			
	$\lambda_d=0,032$	$\lambda_d=0,035$	$\lambda_d=0,037$	
200	0,160	0,171	0,178	REI15 1)
220	0,146	0,157	0,164	
250	0,130	0,140	0,146	
300	0,109	0,118	0,123	
350	0,095	0,102	0,107	
400	0,084	0,090	0,094	
450	0,075	0,081	0,085	
500	0,068	0,073	0,076	

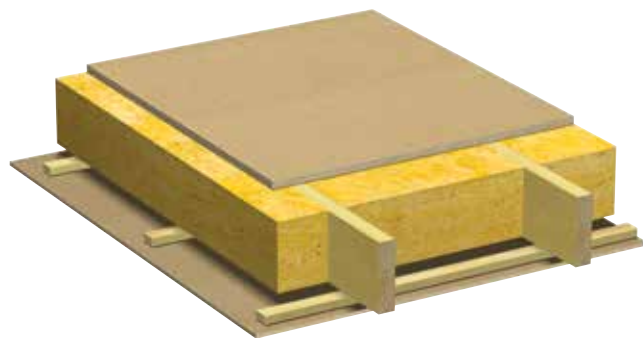

Fig. 3 Beam structure
Beam structure of timber floor beams, fully insulated with ceiling on laths directly to the floor beams 1).

BEAM STRUCTURE	
Underfloor	22 mm Forestia chipboard floor
Floor beam	Timber, glued laminated wood or LVL
Insulation	Insulation with a thickness as the beam height of mineral wool, with U values in accordance with the table; other insulation must have documented fire characteristics
Ceiling	23x48 laths, c/c 600 mm attached directly under the floor beams. One layer of 11 mm Focus MDF board, alternatively a layer of 12 mm Forestia chipboard, or a layer of 11 mm Huntonit wood fibreboard. 1) If 13 mm standard gypsum boards are used, the fire resistance is increased to REI30.

Beam height and insulation thickness	U values (W/m ² K)			Fire resistance
	Insulation with heat conductivity			
	$\lambda_d=0,032$	$\lambda_d=0,035$	$\lambda_d=0,037$	
200	0,168	0,179	0,186	REI15 1)
220	0,155	0,164	0,171	
250	0,138	0,147	0,153	
300	0,117	0,125	0,130	
350	0,102	0,109	0,113	
400	0,090	0,096	0,100	

1) Remark to Figure 1-3 beam structure.
If this is solely to fulfil fire requirements, 150 mm mineral wool is sufficient. The mineral wool must enclose the sides of the Masonite beam's bottom flange. When timber floor beams are used, or profiled I-beam insulation resting on the bottom flange is not used, the insulation must have steel wire protection to prevent it from falling down.

SOUND BEAM STRUCTURE

Airborne sound

Airborne sound insulation for sound beam structure R_w , measured in dB. Airborne sound insulation is the field-measured reduction of airborne sound that can be expected through the separating floor in a final building. The higher the value, the better the airborne sound insulation. The field-measured value is subject to the requirements in the regulations. In the regulations, the airborne sound insulation is recommended not to be lower than 55 dB for separating floors in timber buildings with several storeys.

Impact sound

Impact sound insulation for sound beam structure, $L_{n,w}$, measured in dB. Impact sound insulation is the field-measured value of e.g. foot traffic on the separating floor that can be expected to penetrate through the structure in the final building. The lower the value, the better the reduction of impact sound. The field-measured value is subject to the requirements in the regulations. In the regulations, impact sound insulation is recommended to be equivalent to or less than 53 dB for separating floors in timber buildings with several storeys.

Fire resistance

Fire resistance is based on tests.

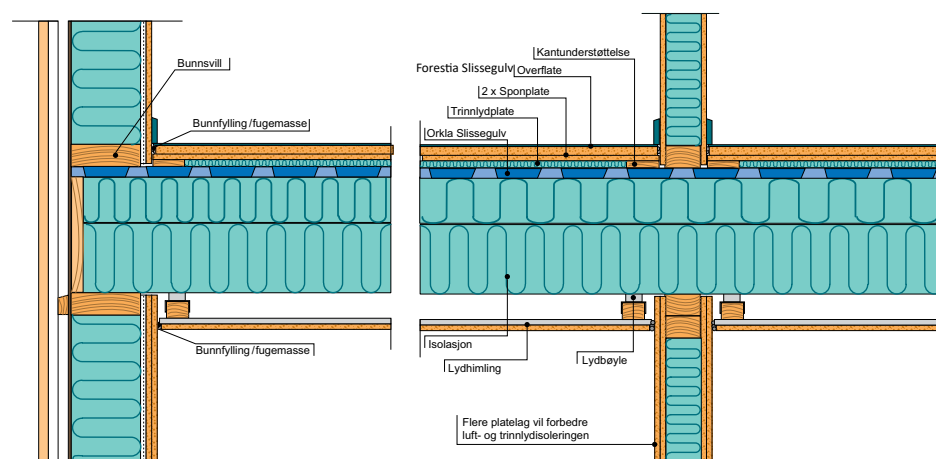

Airborne sound insulation, $R_w + C_{50-5000}$	Impact sound insulation, $L_{n,w} + C_{1,50-5000}$
>55dB	<53dB

Table showing limit values for sound class C according to NS 8175.

Fig. 1 Sound beam structure
General text/images about sound beam structures showing and describing requirements of sealing, edge support, minimum quality of standard gypsum boards and fire gypsum boards, etc.

The following should be observed in order to achieve the best possible sound prevention structure:

- The beam structure is recommended to be dimensioned in accordance with the beam structure table for the Comfort criterion, and account should be taken of any reduction factors for ceiling and underlay type.
- Light metering from beam structure tables should not be reduced because more rigid beam structures are better than less rigid, on audio-technical grounds.
- Follow the manufacturers' installation instructions on installing the ceiling, with the help of audio brackets and laths, or acoustic profiles. This is important so that these are subject to the right load/area, in order to function optimally.
- The ceiling must be built up with soundwave-reducing panels in minimum two layers.
- A floating floor on an impact-sound reducing underlay gives minimal flank transmission.
- An air-open subfloor (Forestia sound-reduction floor) is necessary to achieve maximum effect from the dampening layer (impact sound panels).
- In addition to the sound properties of the actual beam structure, account must also be taken of how other sound transmission routes may be limiting factors. There should be special focus on the link between the beam structure and other bearing structures. Very accurate sealing is required. This and other important elements are described in SINTEF Building Research, construction detail 522.511.

SOUND BEAM STRUCTURE

Beam structure

The beam structures are shown in the tables for each figure.

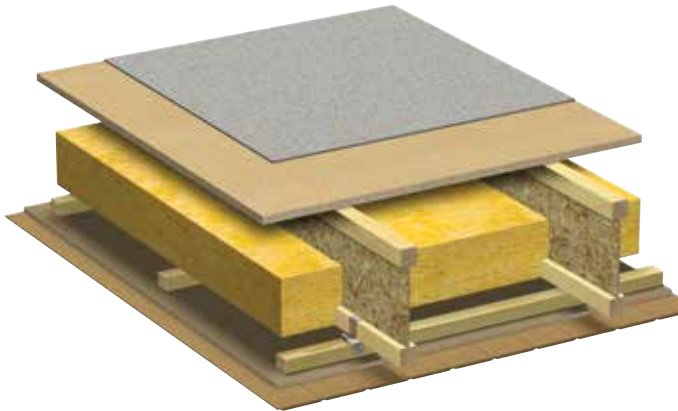

Fig. 2 Sound beam structure
Masonite floor beams with ceiling of two panel layers, see structure.

BEAM STRUCTURE	
Above underfloor	Surfacing
Underfloor	22 mm Forestia chipboard floor
Floor beam	Masonite I-beam
Insulation	Minimum 150 mm mineral wool. The mineral wool must enclose the sides of the Masonite beam's bottom flange. If profiled I-beam insulation resting on the bottom flange is not used, the insulation must be protected with steel wire from falling down.
Ceiling	Audio brackets, 30x48 laths c/c 600, one layer of 12 mm Forestia chipboard and one layer of 11 mm Huntonit wood fibreboard below. The bottom layer may alternatively be 12 mm Forestia chipboard or 11 mm Huntonit MDF.

Fire: REI 30
Impact sound: 65 dB
Airborne sound: 55 dB

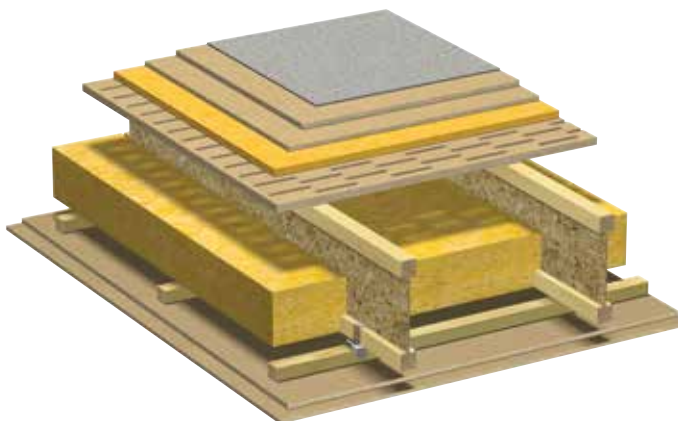

Fig. 3 Sound beam structure
Masonite floor beams with ceiling of two panel layers, see structure.

BEAM STRUCTURE	
Above underfloor	20 mm impact sound panel, 12 mm + 16 mm Forestia Chipboard and surfacing.
Underfloor	22 mm Forestia sound-reduction floor
Floor beam	Masonite I-beam
Insulation	Minimum 150 mm mineral wool. The mineral wool must enclose the sides of the Masonite beam's bottom flange. If profiled I-beam insulation resting on the bottom flange is not used, the insulation must be protected with steel wire from falling down.
Ceiling	Audio brackets, 30x48 laths c/c 600, one layer of 12 mm Forestia chipboard and one layer of 11 mm Huntonit wood fibreboard below.

Fire: REI 30
Impact sound: 48-50 dB
Airborne sound: 55 dB

SOUND BEAM STRUCTURE

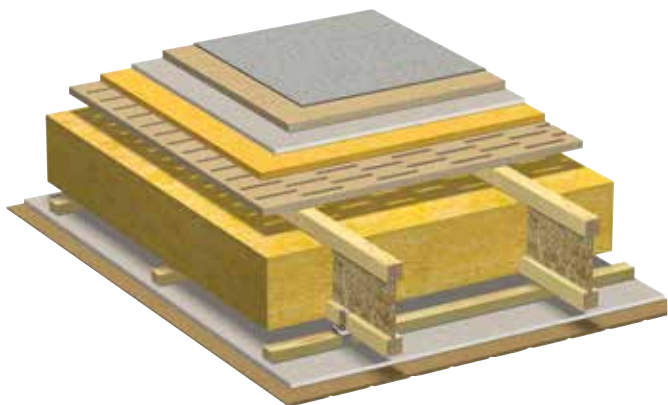

Fig. 4 Sound beam structure
Masonite floor beams with ceiling of two panel layers, see structure.

BEAM STRUCTURE	
Above underfloor	20 mm impact sound panel, 13 mm gypsum board panel, 22 mm Forestia Chipboard and surfacing.
Underfloor	22 mm Forestia sound-reduction floor
Floor beam	Masonite I-beam
Insulation	Minimum 150 mm mineral wool. The mineral wool must enclose the sides of the Masonite beam's bottom flange. If profiled I-beam insulation resting on the bottom flange is not used, the insulation must be protected with steel wire from falling down.
Ceiling	Audio brackets, 30x48 laths c/c 600, one layer of 13 mm gypsum board panel, and one layer of 11 mm Huntonit wood fibreboard below.

Fire: REI 30
Impact sound: 48-50 dB
Airborne sound: 55 dB

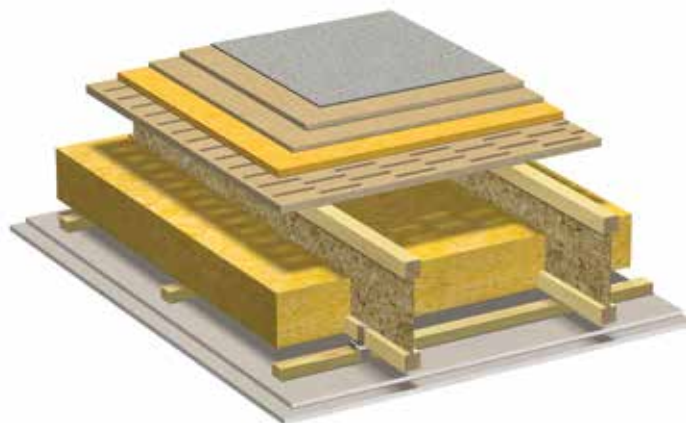

Fig. 5 Sound beam structure
Masonite floor beams with ceiling of two panel layers, see structure.

BEAM STRUCTURE	
Above underfloor	20 mm impact sound panel, 12 mm + 16 mm Forestia Chipboard and surfacing.
Underfloor	22 mm Forestia sound-reduction floor
Floor beam	Masonite I-beam
Insulation	Minimum 150 mm mineral wool. The mineral wool must enclose the sides of the Masonite beam's bottom flange. If profiled I-beam insulation resting on the bottom flange is not used, the insulation must be protected with steel wire from falling down.
Ceiling	Audio brackets, 30x48 laths c/c 400, one layer of 13 mm gypsum board panels and one layer of 15 mm fire gypsum boards below.

Fire: REI 60
Impact sound: 48-50 dB
Airborne sound: 55 dB

SOUND BEAM STRUCTURE

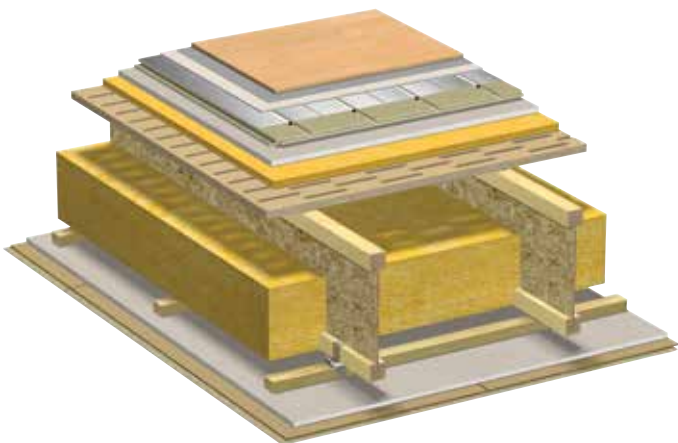

Fig. 6 Sound beam structure
Masonite floor beams with ceiling of two panel layers,
see structure.

BEAM STRUCTURE	
Above underfloor	20 mm impact sound panel, 12 mm renovation floor, 22 mm Forestia Thermo floor, 3 mm Etafoam and parquet/laminate.
Underfloor	22 mm Forestia sound-reduction floor
Floor beam	Masonite I-beam
Insulation	Minimum 200 mm mineral wool. The mineral wool must enclose the sides of the Masonite beam's bottom flange. If profiled I-beam insulation resting on the bottom flange is not used, the insulation must be protected with steel wire from falling down.
Ceiling	Audio brackets, 30x48 laths c/c 600, one layer of 13 mm gypsum board panels and one layer of 12 mm Forestia Tak-Ess below.

Fire: REI 30
Impact sound: 50 dB
Airborne sound: 62 dB

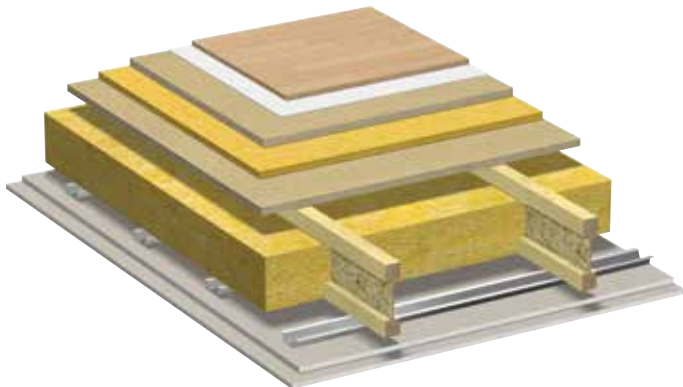

Fig. 7 Sound beam structure
Masonite floor beams with ceiling of two panel layers,
see structure.

BEAM STRUCTURE	
Above underfloor	20 mm impact sound panel, 22 mm Forestia standard chipboard floor, 3 mm Etafoam, 14 mm parquet
Underfloor	22 mm Forestia standard chipboard floor
Floor beam	Masonite I-beam
Insulation	Minimum 150 mm mineral wool. The mineral wool must enclose the sides of the Masonite beam's bottom flange. If profiled I-beam insulation resting on the bottom flange is not used, the insulation must be protected with steel wire from falling down.
Ceiling	25 mm acoustic rail/c 400, one layer of 13 mm gypsum board, and one layer of fire gypsum board below.

Fire: REI 60
Impact sound: 48-50 dB
Airborne sound: 58 dB

SOUND BEAM STRUCTURE

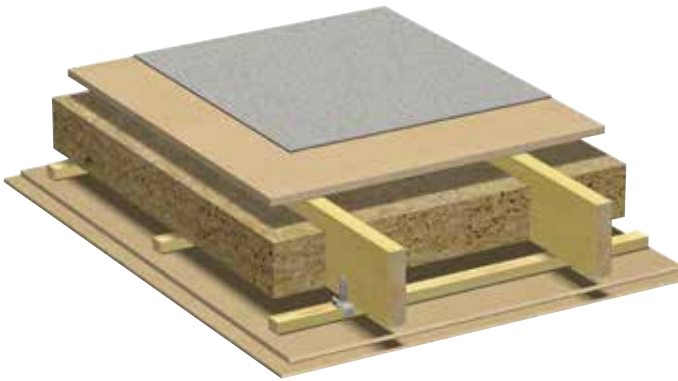

Fig. 8 Sound beam structure
Timber floor beams with ceiling of two panel layers,
see structure.

BEAM STRUCTURE	
Above underfloor	Surfacing
Underfloor	22 mm Forestia chipboard floor
Floor beam	Timber floor beam, 48x198 mm
Insulation	Minimum 150 mm Rockwool mineral wool. The insulation is protected with steel wire from falling down.
Ceiling	Audio brackets, 30x48 laths c/c 600, two layers of 12 mm Forestia chipboard.

Fire: REI 60
Impact sound: 65 dB
Airborne sound: 55 dB

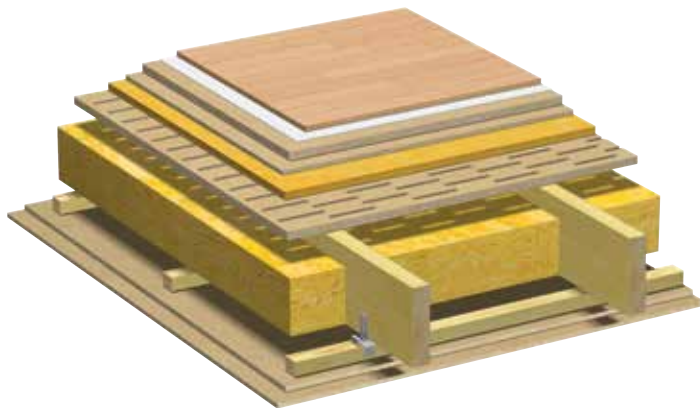

Fig. 9 Sound beam structure
Timber floor beams with ceiling of two panel layers,
see structure.

BEAM STRUCTURE	
Above underfloor	20 mm impact sound panel, 22 mm Forestia standard chipboard floor, 3 mm Etafoam, 14 mm parquet
Underfloor	22 mm Forestia chipboard floor
Floor beam	Timber floor beam 48x198 mm
Insulation	Minimum 150 mm mineral wool. The insulation is protected with steel wire from falling down.
Ceiling	Audio brackets, 30x48 laths c/c 600, two layers of 12 mm Forestia chipboard.

Fire: REI 60
Impact sound: 48-50 dB
Airborne sound: 58 dB

SOUND BEAM STRUCTURE

A change in the execution described in the figures for sound beam structures would entail changes in the structures' fire and sound characteristics.

Two tables showing changes in the structure and consequences of this for the sound beam structure characteristics.

Figure nr.	Sound insulation (db)		Fire resistance	Remark
	Impact sound L`nw	Airborne sound R`w		
2	65	55	REI30	2), 3)
3	48-50	55	REI30	1), 2), 3)
4	48-50	55	REI30	1), 2), 3), 4)
5	48-50	55	REI60	
6	50	62	REI30	1), 2), 3), 5)
7	48-50	58	REI60	
8	65	55	REI60	3)
9	48-50	58	REI60	3)

Remark	Change	Impact sound L`nw	Airborne sound R`w	Fire resistance
1)	30x48 laths c/c 400. One layer of 13 mm gypsum board, and one layer of 15 mm fire gypsum board below.	As figure	As figure	REI60
2)	Change from the described timber-based panels in the ceiling to other panels of the Forestia chipboard, Hunttonit wood fibreboard or Focus MDF type.	As figure	As figure	As figure
3)	Change from the described panels in the ceiling where by one or both layers are standard gypsum boards.	As figure	As figure	As figure
4)	Impact sound moulding between double top sills.	48-51 dB	61 dB	As figure
5)	12 mm Forestia renovation floor and felt instead of 13 mm gypsum.	As figure	As figure	As figure

Example of changes in figure 6 sound beam structure:

Requirement to fulfil fire requirement REI60.

Footnote 1) Change to 30x48 laths c/c 400. One layer of 13 mm gypsum board, and one layer of 15 mm fire gypsum board below.

Example of changes in figure 2 sound beam structure:

Requirement to change ceiling panels to standard gypsum.

Footnote 3) the change gives no changes in relation to documented sound or fire characteristics.

COVERING

Sound and fire prevention characteristics of heavy separating floors of light clinker, cavity covering and concrete

The characteristics of heavy separating floors with floating floors of board materials on impact-sound dampening mineral wool layers are described in Building Research Design Guides 522.513 and 522.515. These details include tables and examples for calculation of impact sound and airborne sound, which also show the fire resistance.

Fig 1. Covering gives an example of a floating floor without panels in the fire resistant ceiling, and sound characteristics obtained from the Building Research Design Guides' construction details.



BEAM STRUCTURE	
Upper covering	20 mm impact sound panel, 22 mm Forestia standard chipboard floor, 3 mm Etafoam and 14 mm parquet
Covering	Lightweight clinker, thickness of 200 mm + slurry. Small/medium flank transmission.

Fire: REI 90
 Impact sound: 53-57 dB
 Airborne sound: 47-55 dB

Fig. 1 Covering.
 Floating floor on lightweight clinker.

WINDOW

Uldal windows and doors

EI-30 (fire retardant window)

Uldal produces fire retardant windows in class EI-30 as fixed sill, top swing and a combination of fixed and top swing in the same sill. The products are manufactured in the same sill/frame execution as our standard products.

All products can be delivered with aluminium cladding as a supplement.

It must not be possible to open fire-resistant windows in ordinary use conditions.

A top-swing window in fire class EI-30 must not be used as a ventilation window. It must be possible to open an opening window with EI-30 approval for maintenance purposes.

Our top-swing windows are delivered with a lockable handle.

Outline drawing for correct sealing around an Uldal EI-30 window.

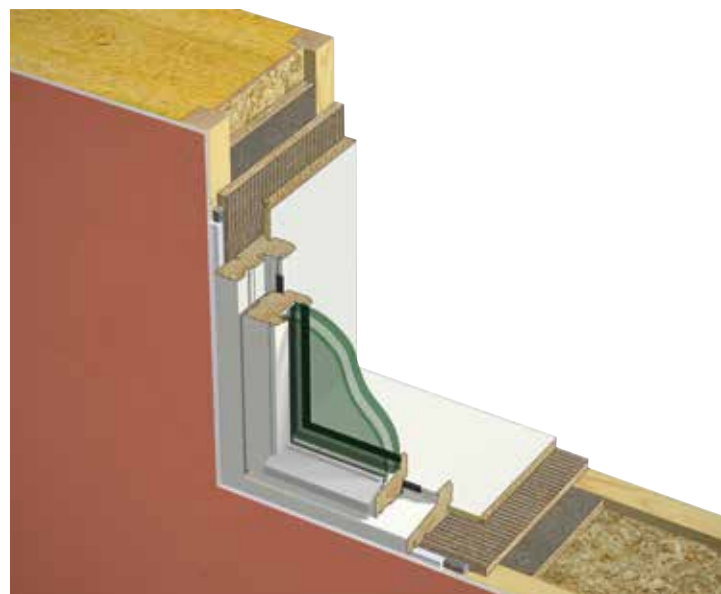
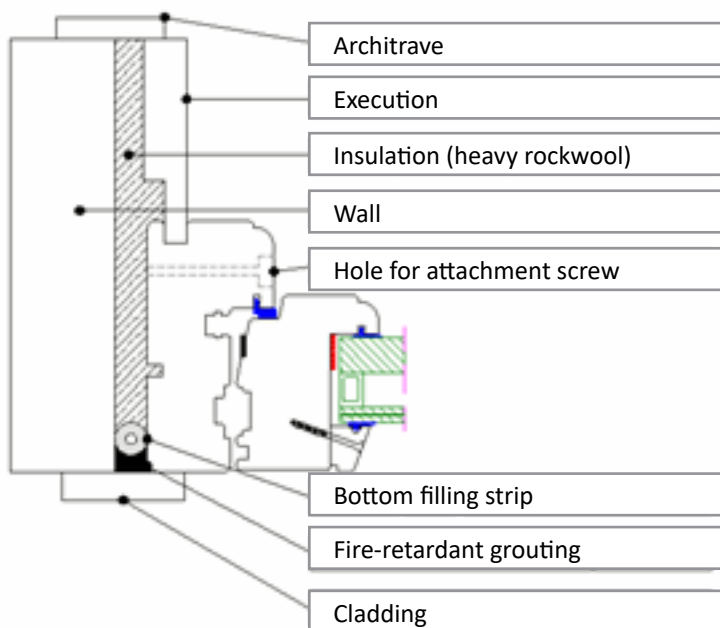

See Building Research Design Guides, construction details 523.701, concerning sealing of windows.

WINDOW

U value

Since 2009, Uldal has delivered windows with U values which are good enough for them to be used in passive buildings (u-0.8) without using extra sealing. Today, we use a laminated sill with a thickness of 115 mm.

A fixed sill can be delivered with a U value of 0.64 and the top-swing window can be delivered with a U value of 0.74. This is far better than the passive building requirement of 0.8.

(The figures are based on a reference window with the dimensions 1230x1480)

See Building Research Design Guides, construction details 523.701, concerning sealing of windows.



Innsetting av vindu i vegger av bindingsverk

Byggforskerien
Byggedetaljer - mars 2012
523.701

0 Generelt

01 Innhold

Denne anvisningen behandler innsetting av vinduer i bindingsverk av tre og bindingsverk av tynnplateprofiler av metall. Anvisningen viser alternative plasseringer i vegg og hvordan vinduet bør monteres og festes. Videre viser anvisningen detaljer for luft- og regntetting av fugen mellom karmen og vegg, samt utførelse av omramning utvendig og innvendig.
Se også Byggedetaljer 523.702 Innsetting av vindu i mur- og betongvegger.

1 Overordnede hensyn

11 Funksjonskrav til innfesting, omramning og tetning

Vindusinnfestingen må være solid. Den skal sikre at vinduet ikke kan falle ut eller blåse inn. For åpningsvinduer må man også sørge for at vinduet fungerer som forutsatt i mange år med åpning og lukking.
Utvendig omramning og tetning skal hindre regn i å trenge inn i vegg via fugen mellom vindu og vegg. Samtidig må fugen være drenert og ha tilstrekkelig utløsningsmulighet til at oppstakete materialer tørker forrest mulig. Fugen må være tilstrekkelig lufttett på både kald og varm side for å hindre gjennomgående luftlekkasjer i fugeisolasjonen.
For lyd- og brannklassifiserte vinduer er det spesielt viktig å følge anvisningen fra produsenten.
Hvordan vinduet plasseres i vegg, påvirker en rekke forhold, se pkt. 2.

12 Dokumentasjon av produkttegenskaper

TEK10 krever at produkttegenskaper som er av betydning for de grunnleggende kravene til byggverk skal være dokumentert før produktet omsettes og brukes. Produktets påvirkning på helse og ytre miljø må dokumenteres. Det settes krav til å begrense innhold av helse- og miljøskadelige kjemikalier, redusere påvirk-

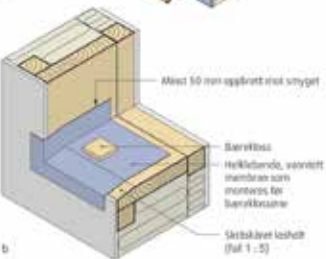
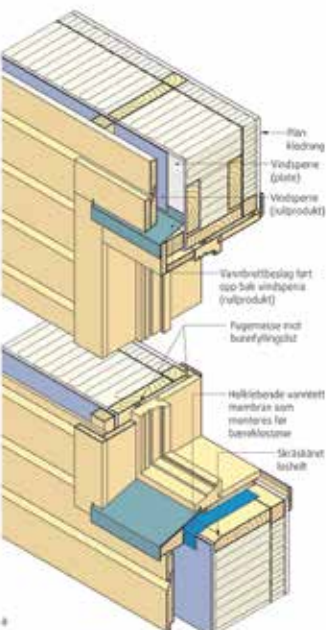

Fig. 241 a og b
Vindu plassert et stykke inn i isolasjonslaget
a. Når oppsettet på vinduet/beslaget ligger inne i vindupers i vegg, stiles det svært strenge krav til beslag og tettedetaljer. For å unngå oppstak av vegg ved lekkasjer rundt vinduet, kreves en effektiv membran under vinduet.
b. Hellebet, vannrett membran må monteres i smygget under vinduet, se pkt. 242 og fig. 21 b.

Plan kleddning
Vindupers (plate)
Vindupers (ulprodukt)
Vannrett beslag fast opp bak vindupers (ulprodukt)
Fugemasse med barefyllingsilt
Hellebetende vannrett membran som monteres for barefylling
Skreddersydd lisholt
Minst 50 mm oppbrent tross smygget
Barefylling
Hellebetende vannrett membran som monteres for barefylling
Skreddersydd lisholt (ful 1-5)

SINTEF Byggtforskning | Pb.124 Blindern - 0314 Oslo | Tlf. 22 96 55 55 | www.sintef.no/byggtforskning | © Copyright

WINDOW

Sound reduction

Sound reduction for windows is more and more common today since we often build more densely and closer to roads.

Uldal's standard window fulfils 32dB (C;-1dB, Ctr;-5dB)

Windows can be delivered up to 43dB (C;-1dB, Ctr;-3dB)

Balcony doors can be delivered up to 42dB (C;-2dB, Ctr;-4dB)

(All values in accordance with reference sizes)

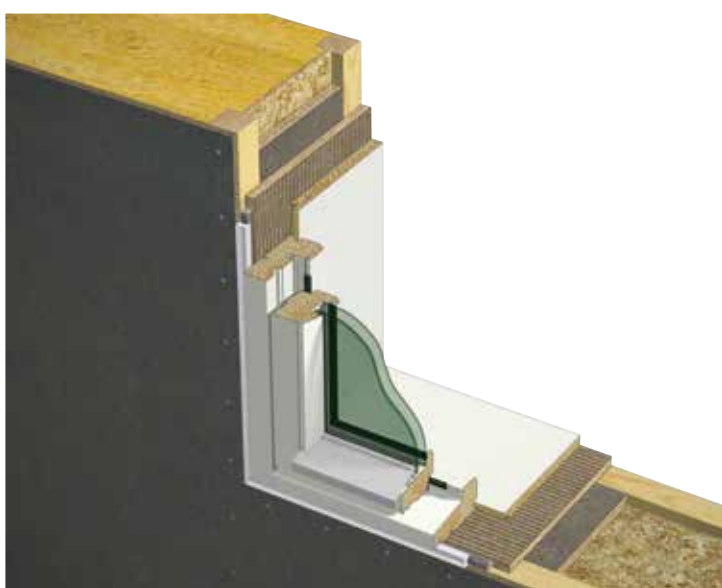

When the requirement of the window's sound insulation R_w+C_{tr} is lower than 32dB, it is recommended to insert the window and seal around it in accordance with Sintef construction details 523.701. (Standard installation).

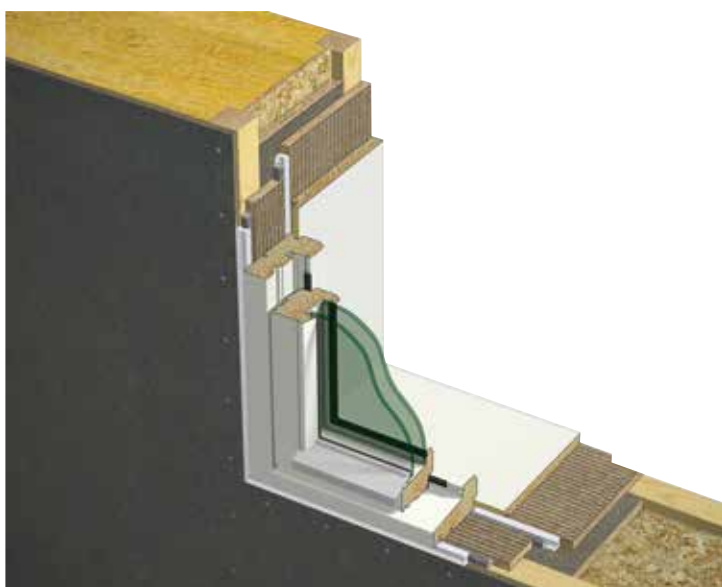

When the requirement of the window's sound insulation R_w+C_{tr} is greater than 32dB, it is recommended to insert the window and seal around it in accordance with Sintef construction details 533.109.